

# CITY OF POST FALLS STANDARD FOR R. P. B.A. INSTALLATION

## RE.: INTERIOR SET (Reduced Pressure Principle Backflow Prevention Assembly)

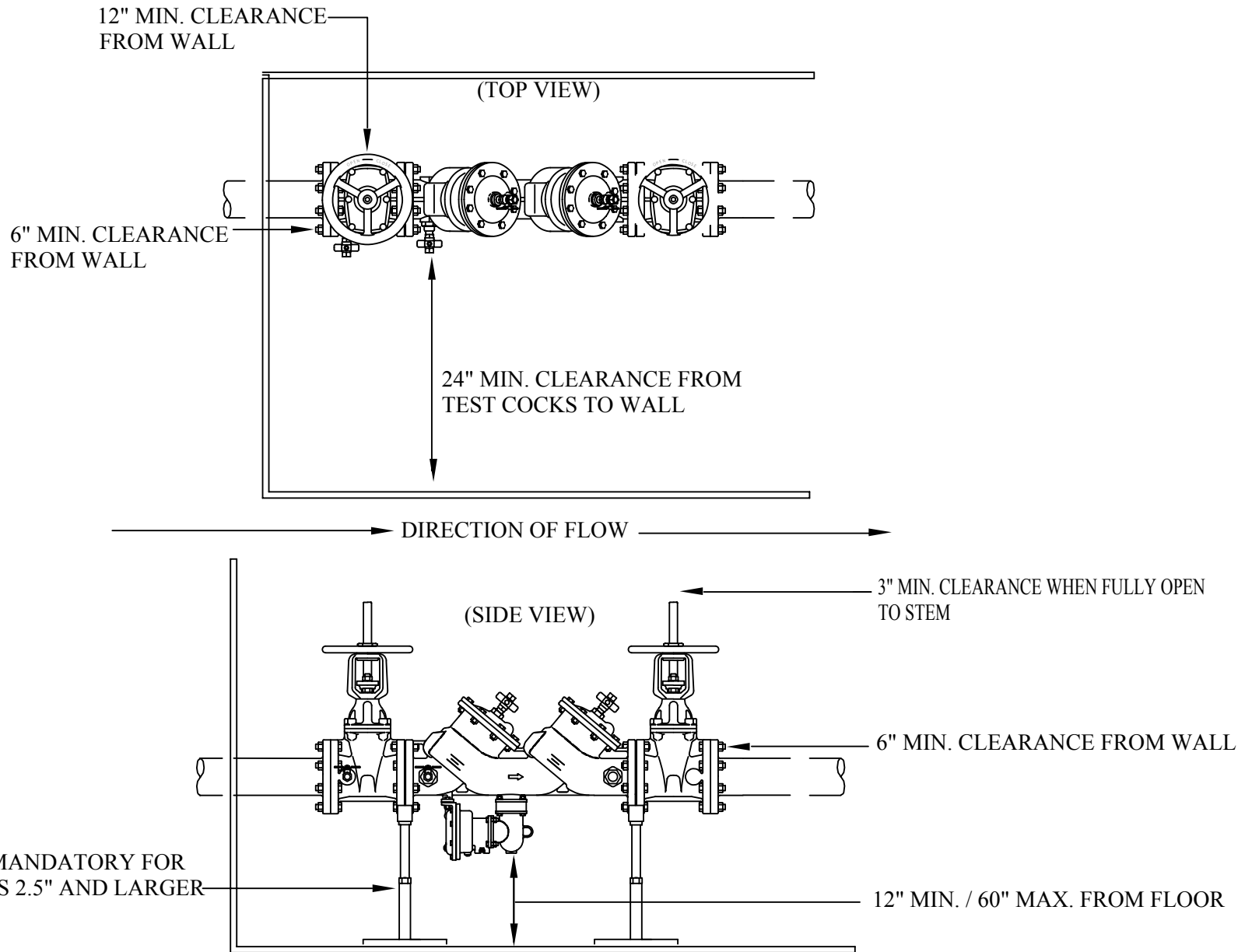

A.W.W.A. Manual of Water Supply Practices M14: "An RP must not be installed in a pit or below grade where the relief valve could become submerged in water or where fumes could be present at the relief-valve discharge, because this installation may allow water or fumes to enter the assembly."

An R.P.B.A. may periodically discharge water from the relief valve. If the RP discharge is piped to a drain, an air-gap separation must be installed at the relief valve.

CITY OF POST FALLS STANDARD FOR R. P. B.A. INSTALLATION  
 RE.: INTERIOR SET (Reduced Pressure Principle Backflow Prevention Assembly)

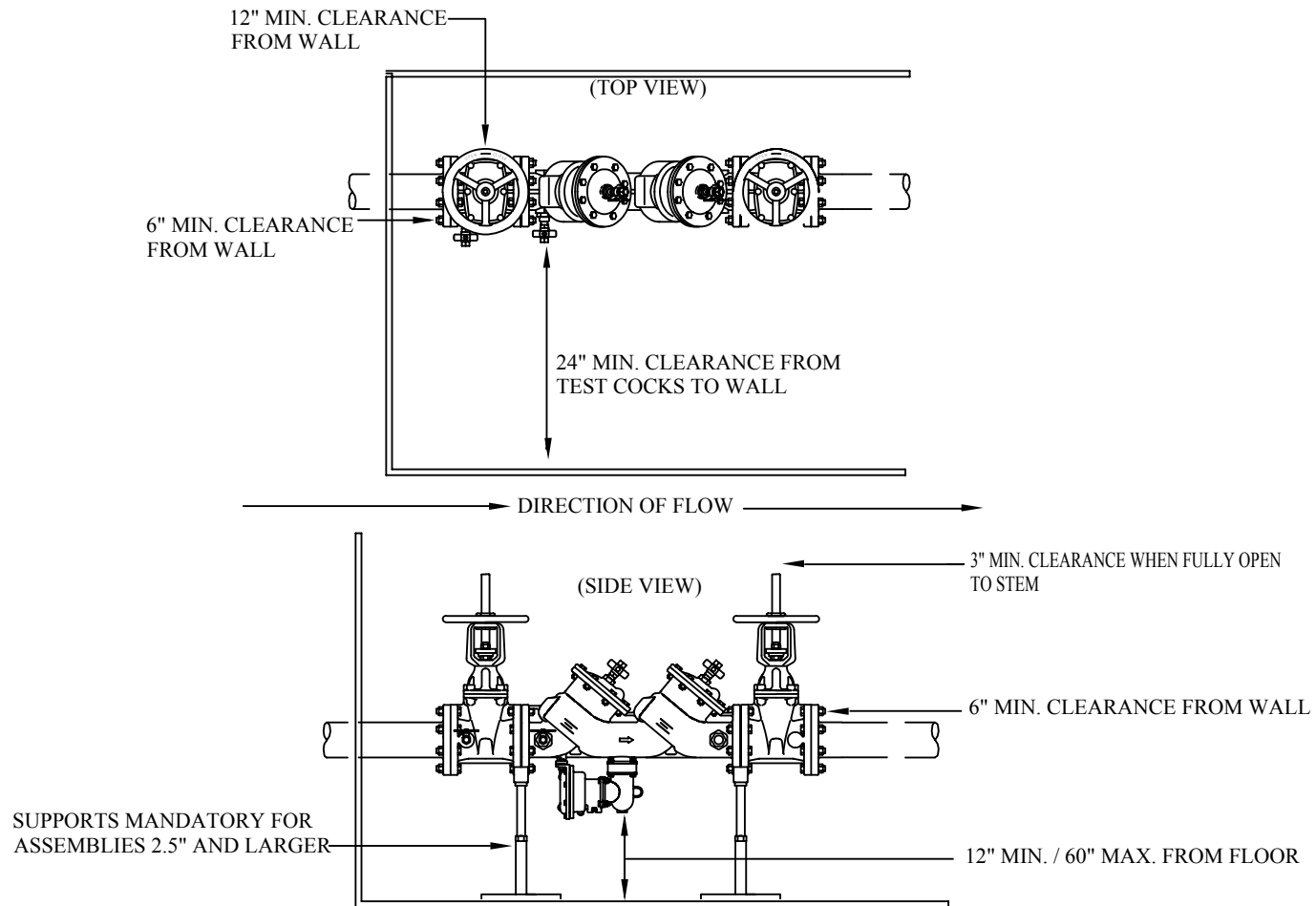

A.W.W.A. Manual of Water Supply Practices M14: "An RP must not be installed in a pit or below grade where the relief valve could become submerged in water or where fumes could be present at the relief-valve discharge, because this installation may allow water or fumes to enter the assembly."

An R.P.B.A. may periodically discharge water from the relief valve. If the RP discharge is piped to a drain, an air-gap separation must be installed at the relief valve.