

NOTES:

1. TOOL JOINTS SHALL BE PLACED EVERY 5 FEET AND MATCH CURB JOINTS.
2. EXPANSION JOINTS SHALL BE PLACED EVERY 20 FEET IN THE SIDEWALK, BETWEEN THE SIDEWALK AND BOARDING/ALIGHTING AREA, AND BETWEEN THE SIDEWALK AND BENCH/CLEAR SPACE AREA. FELT EXPANSION MATERIAL SHALL EXTEND THE FULL SIDEWALK DEPTH.
3. ALL SURFACES, WITH THE EXCEPTION OF THE PEDESTRIAN RAMP, SHALL HAVE A MAXIMUM CROSS SLOPE OF 2%.
4. BOARDING AND ALIGHTING AREAS SHALL HAVE A MAXIMUM SLOPE OF 2% IN ANY DIRECTION.
5. WITH ROLLED CURB AND GUTTER, THE INSIDE PED RAMP FLAIR IS REDUCED FROM A 6FT TO A 3FT WING.
6. TACTILE WARNING SURFACES, PEDESTRIAN RAMP SECTIONS AND ADJOINING LANDINGS SHALL COMPLY WITH SD 2013.
7. PROVIDE CURB CUTS FOR DRAINAGE ON EITHER SIDE OF BUS STOP AS REQUIRED BY THE CITY.
8. BENCHES SHALL HAVE A FRONT EDGE SEAT HEIGHT BETWEEN 7 INCHES MIN. AND 19 INCHES MAX.
9. FINISHED WORK EXCEEDING MAXIMUM SLOPES OR LESS THAN MINIMUM DIMENSIONS WILL BE REJECTED. MAXIMUM AND MINIMUM VALUES ARE ABSOLUTE.

TYPICAL CROSS SECTION

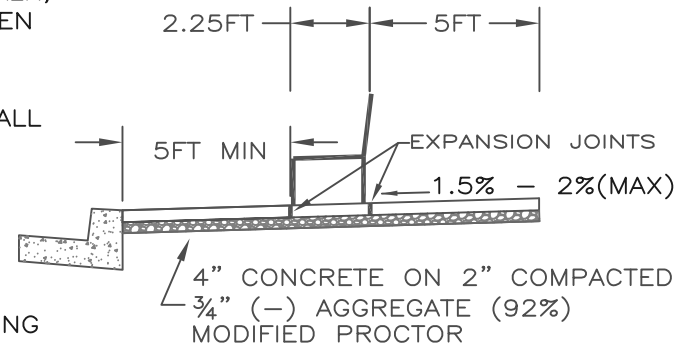

APPROVED BY:

POST FALLS STANDARDS FOR PUBLIC WORKS CONSTRUCTION

[Signature] 3/19/19
CITY ENGINEER, P.E. DATE:

BUS STOP AT SWALE SECTIONS

STANDARD DRAWING
NO. BD 01